

1. MECHANICAL DIMENSIONS :

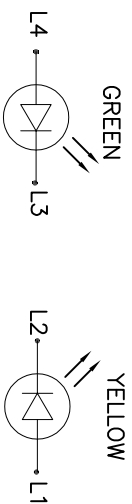

LED CONFIGURATION

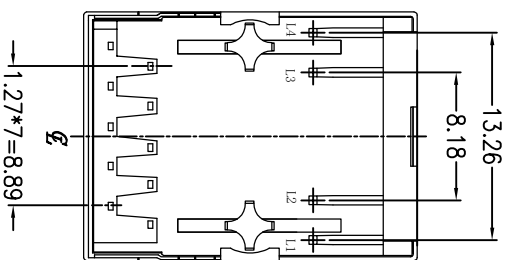
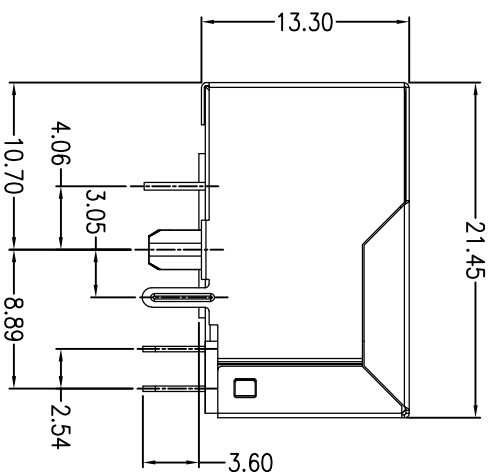
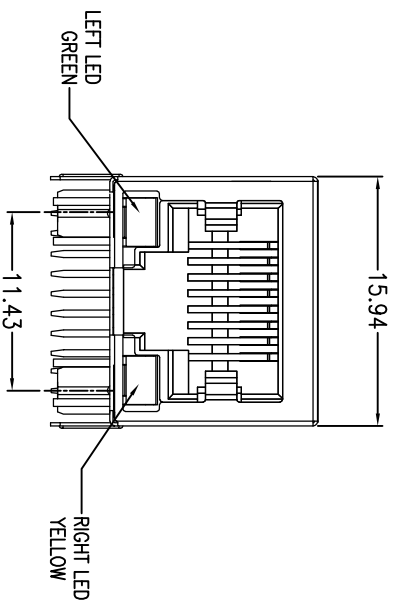
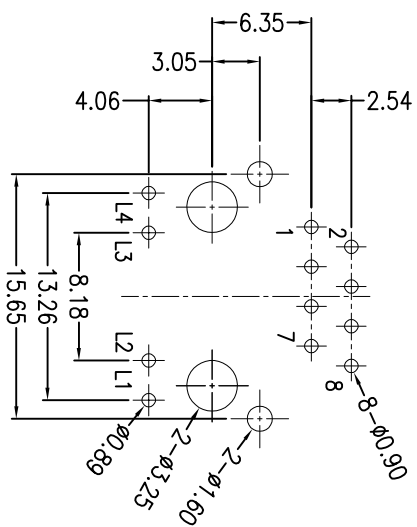

RECOMMEND PCB LAYOUT  
(TOP VIEW)

DIMENSIONAL TOLERANCE: ±0.05

NOTES:

- 1 MATERIAL:
- HOUSING: PBT BLACK UL94V-0
- CONTACTS: PHOSPHOR BRONZE T=0.35
- G/F ON CONTACT AREA, TIN PLATING ON SOLDER TAIL
- SHIELD : COPPER ALLOY T=0.20
- NICKEL PLATING OVERALL
2. CAVITY CONFIRMS TO FCC RULES AND REGULATIONS
- PART 68,SUBPART F.

**JAN** 东莞市建旭电子有限公司  
**ANSUM ELECTRONICS (DONGGUAN)CO.,LTD**  
[Http://www.jansum.cn](http://www.jansum.cn)

APPROVE	SIZE: A4	SCALE 2:1	UNITS MM	GENERAL TOLERANCE
CHECK	REV/ ECN NUMBER	DATE	DRAW	X ± 0.38
DRAW	A NEW	2021-7-6	ZHANGYANBIN	.XX ± 0.25
				.XXX ± 0.13

DWG NO.	TITLE:
H1112002Y	1X1 TAB DOWN RJ45 MAGACK W/SHELL&LED DIP TYPE(10/100 BASE-T)

REV	SHEET
A	1 / 2

NOTE : ◇ EC ● DIM NUMBER ■ QC INSPECTION ITEM ▼ CPK ITEM

DOCUMENT NO.:

2. SCHEMATIC:

CONNECTOR SOLDER SIDE

RJ45 CONTACT SIDE

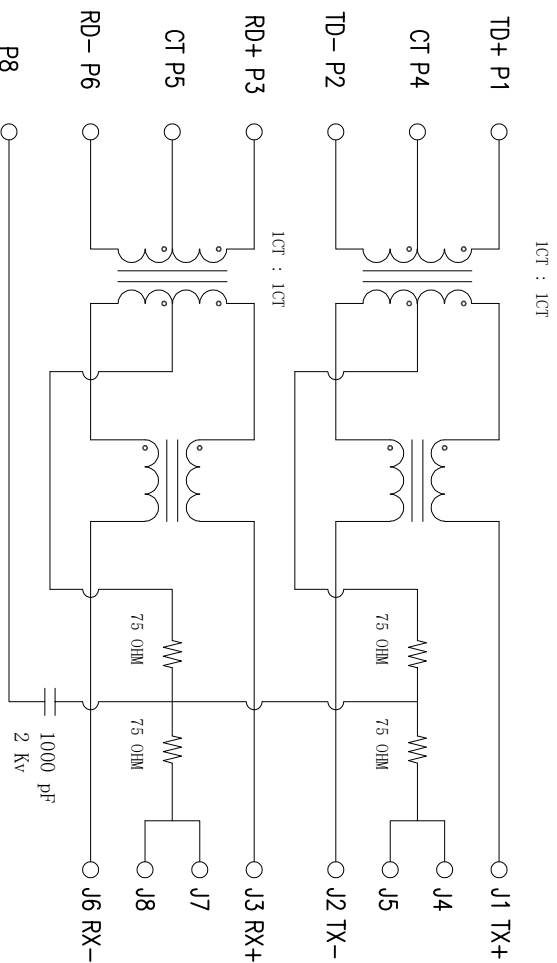

- ELECTRICAL CHARACTERISTICS(25±5°C)
- TR:(100KHz,0.1V): 100%
  - INS:(P1,P2):(J1,J2)=1:1±3%;(P3,P6):(J3,J6)=1:1±3%
  - LX:(100KHz,100mV,8mA, DC Bias) 100%
  - INS:(P1,P2),(P3,P6)=350uH MINIMUM
  - DCR: 100%
  - INS:(J1,J2),(J3,J6)=1.2 Ω MAXIMUM
  - HPOT: 100%
  - INS(P1,P2)TO(J1,J2),(P3,P6)TO(J3,J6)=1500VAC FOR 60 SECONDS
  - INSERTION LOSS:
    - 1.0dB MAXIMUM AT 1MHz TO 100MHz;
    - 18dB MINIMUM AT 1MHz TO 30MHz;
    - 16dB MINIMUM AT 30MHz TO 60MHz;
    - 12dB MINIMUM AT 60MHz TO 80MHz
  - CROSS TALK:
    - 30dB MINIMUM AT 1MHz TO 100MHz
  - COMMON TO COMMON MODE REJECTION:
    - 30dB MINIMUM AT 1MHz TO 100MHz

**JAN** 东莞市建旭电子有限公司  
 JANSUM ELECTRONICS (DONGGUAN)CO.,LTD  
 Http://www.jansum.cn

APPROVE	SIZE: A4	SCALE 2:1	UNITS MM
CHECK	REV/ ECN NUMBER	DATE	DRAW
DRAW	A / NEW	2021-7-6	ZHANGYANBIN

GENERAL TOLERANCE	X.± 0.38	X.± 2
	.XX± 0.25	.X± 1
	.XXX± 0.13	

DWG NO.	H1112002Y	REV	A
TITLE:	IX1 TAB DOWN RJ45 MAGACK W/SHELL&LED DIP TYPE(10 /100 BASE-T)	SHEET	2 / 2

NOTE : ◇ EC ● DIM NUMBER ■ QC INSPECTION ITEM ▼ CPK ITEM

DOCUMENT NO.: